

This article was downloaded by:

On: 22 January 2011

Access details: *Access Details: Free Access*

Publisher *Taylor & Francis*

Informa Ltd Registered in England and Wales Registered Number: 1072954 Registered office: Mortimer House, 37-41 Mortimer Street, London W1T 3JH, UK



## The Journal of Adhesion

Publication details, including instructions for authors and subscription information:

<http://www.informaworld.com/smpp/title~content=t713453635>

### A Photoelastic Study of the Stress Distribution in Adhesively Bonded Joints with Prebent Adherends

E. Sancaktar<sup>a</sup>; P. O. Lawry<sup>a</sup>

<sup>a</sup> Mechanical and Industrial Engineering Department, Clarkson College of Technology, Potsdam, New York, U.S.A.

**To cite this Article** Sancaktar, E. and Lawry, P. O.(1980) 'A Photoelastic Study of the Stress Distribution in Adhesively Bonded Joints with Prebent Adherends', *The Journal of Adhesion*, 11: 3, 233 – 241

**To link to this Article:** DOI: 10.1080/00218468008078919

**URL:** <http://dx.doi.org/10.1080/00218468008078919>

PLEASE SCROLL DOWN FOR ARTICLE

Full terms and conditions of use: <http://www.informaworld.com/terms-and-conditions-of-access.pdf>

This article may be used for research, teaching and private study purposes. Any substantial or systematic reproduction, re-distribution, re-selling, loan or sub-licensing, systematic supply or distribution in any form to anyone is expressly forbidden.

The publisher does not give any warranty express or implied or make any representation that the contents will be complete or accurate or up to date. The accuracy of any instructions, formulae and drug doses should be independently verified with primary sources. The publisher shall not be liable for any loss, actions, claims, proceedings, demand or costs or damages whatsoever or howsoever caused arising directly or indirectly in connection with or arising out of the use of this material.

## NOTE

# A Photoelastic Study of the Stress Distribution in Adhesively Bonded Joints with Prebent Adherends†

E. SANCAKTAR AND P. O. LAWRY

*Mechanical and Industrial Engineering Department  
Clarkson College of Technology, Potsdam, New York 13676 U.S.A.*

*(Received Feb. 12, 1980; in final form July 2, 1980)*

A photoelastic study on lap joints with inflexible adhesive layers reveals that the load carrying capacity may be increased as much as 71% with the use of prebent adherends.

## INTRODUCTION

In aerospace and automotive industries components, which are made of lightweight, composite, or plastic materials are usually bonded in the form of lap joints.

Goland and Reissner<sup>1</sup> obtained analytical solutions for such joints by applying restrictions on the ratios of adhesive and adherend moduli and thicknesses. They neglected the flexibility of the bond when the ratio of the adhesive thickness to modulus was less than or equal to one tenth of the same ratio for the adherend. Joints with adhesive thickness to modulus ratios greater than or equal to ten times the same ratio for the adherend were categorized as joints with flexible bonds.

Goland and Reissner showed that high stress concentrations existed near each end of the overlap region in the form of peak normal (tearing) adhesive stress for the joints with inflexible bonds and in the form of peak normal and shear adhesive stresses for the joints with flexible bonds.

In practical applications bonded metal plates are considered joints with flexible adhesive layers. Bonded plastic or composite adherends,

---

† Presented at the Annual Meeting of The Adhesion Society, Savannah, GA, U.S.A., February 10-13, 1980.

however, usually fall into the category of joints with inflexible adhesive layers, as such materials have elastic moduli of a couple of million psi or less.

By using an analysis similar to Goland and Reissner, DasGupta and Sharma<sup>2,3</sup> showed that the peak adhesive stresses decreased with the use of prebent adherends (Figure 1). Their analysis covered only the case of joints with flexible bonds and showed that the load carrying capacity was increased by 63% and 135% over the ordinary joints (0 degrees prebent) when prebent angles of 5 and 10 degrees, respectively, were used. DasGupta and Sharma<sup>2,3</sup> used joints with steel adherends and EPON 828 adhesive to verify their analytical results. Theory and experiment showed good agreement when the maximum normal stress criterion was used for joint strength.

This paper presents the results of photoelastic experiments on lap joints with prebent adherends and inflexible adhesive layers. These results contain the effect of tensile load on bend angles (the prebent angle does not remain constant during loading, therefore, the prebent angles will be called bend angles when subjected to loading); a comparison of experimental results with Goland and Reissner theory for ordinary joints (0 degrees prebent) with 2.0 in. (50.8 mm) and 0.3 in. (7.6 mm) overlap lengths; and the effect of tensile load on the adhesive peak tearing stresses.

## EXPERIMENTAL PROCEDURE

Model joint adherends were machined from Columbia Resin (CR-39) and bonded with liquid plastic cement (PMC-1). Both the adhesive and adherend materials were products of Photolastic Inc. (Malvern, PA).

As reported by the manufacturer, Young's moduli for the adherend and adhesive materials were  $3.00 \times 10^5$  psi ( $2.07 \times 10^3$  MPa) and  $4.25 \times 10^5$  psi ( $2.93 \times 10^3$  MPa) respectively. Poisson's ratios were 0.57 for the adherend (measured in-house) and 0.36 for the adhesive (reported by the manufacturer).

Model specimens had 0°, 5°, 9°, and 15° prebent angles and 2.0 in. (50.8 mm) overlap lengths. Other dimensions for model specimens are shown in Figure 1.

Another 0° prebent specimen with 0.3 in. (7.6 mm) overlap length was also prepared to be used for the comparison of photoelastic results with Goland and Reissner theory.

Specimens were loaded and examined on a transmission polariscope. They were attached to the polariscope by using movable pinned grips, and were loaded in tension. Isoclinic and isochromatic fringe patterns were observed and photographed by using plane and circular polariscope settings at nine or more load levels. Loading was halted when the isochromatic fringe order indicated possible failure at some point on the specimen.

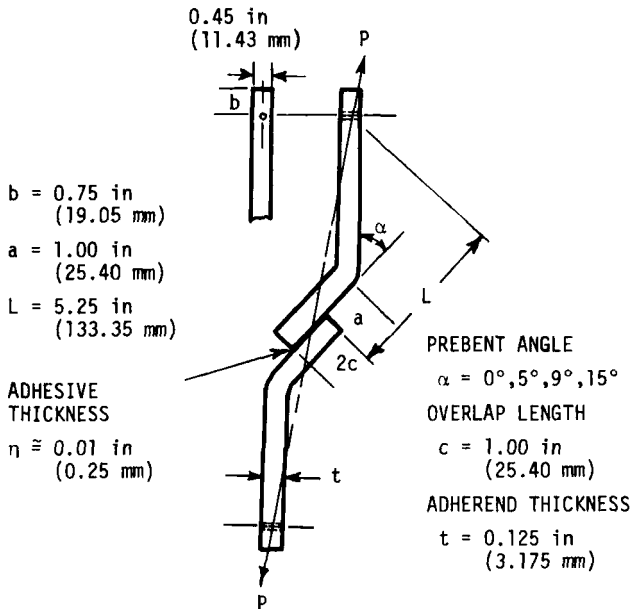

FIGURE 1 Lap Joint with Prebent Adherends.

The load level was increased in steps and data were taken in a short time (in less than a minute) to avoid creep in the joint. Specimen edges were carefully wet polished to avoid residual stresses caused by machining. Specimens were kept and tested at room temperature to avoid thermal stresses. Residual stresses were determined for each specimen before loading and were taken into account during the calculation of stresses due to loading.

### Interpretation of the Isochromatic Data

Figure 2 illustrates the interpretation of the isochromatic data. Since a light background is used, the white and black fringes represent whole and half orders respectively. The white fringe on the outer corner of the adherend is of zero order as all of the stresses there are zero. The fringe order on the overlap area increases towards the bondline, reaching the order of two at the inside corner of the overlap, on the adhesive layer boundary. As the adhesive and adherend moduli are of the same order of magnitude, the stresses can be assumed continuous between the adherend and the adhesive. Hence the adhesive peak tearing stress ( $\sigma_N$ , acting through adherend outer edge in Figure 2) at the inside corner is the only nonzero adhesive stress at that point, as reported by Goland and Reissner<sup>1</sup>. For this free boundary-condition, the only nonzero principal stress  $\sigma_N$ , which is tangential to the

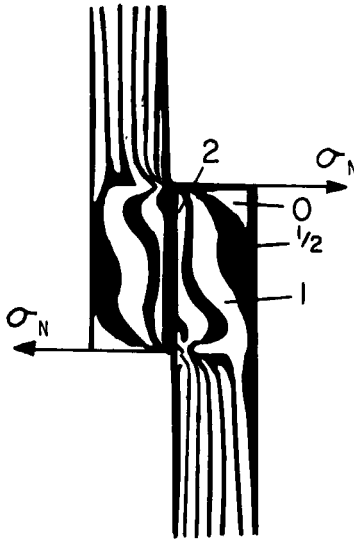

FIGURE 2 Interpretation of the Isochromatic Data

boundary, can be calculated readily<sup>4</sup> from the isochromatic fringe order at that point by using the relation

$$\sigma_N = \frac{nf}{h}$$

where  $n$  is the isochromatic fringe order,  $f$  ( $= 120$  psi/fringe/in.;  $2102$  kPa/fringe/cm, as reported by the manufacturer), is the material fringe constant and  $h$  ( $= 0.45$  in;  $11.43$  mm) is the material thickness (adherend width). For example, in Figure 2 the value of adhesive peak tearing stress,  $\sigma_N$  is  $533$  psi ( $3676$  kPa).

## RESULTS AND DISCUSSION

Before presenting the results on the effect of tensile load on the adhesive peak tearing stress, a discussion of the tensile load *vs.* the bend angle behavior will be helpful as peak tearing stresses are affected by the magnitude of bend angles.

### Load Dependence of the Bend Angle

The adherend stiffness of a joint with inflexible adhesive layer is usually much less than that of a metal adherend. For this reason the prebent angle

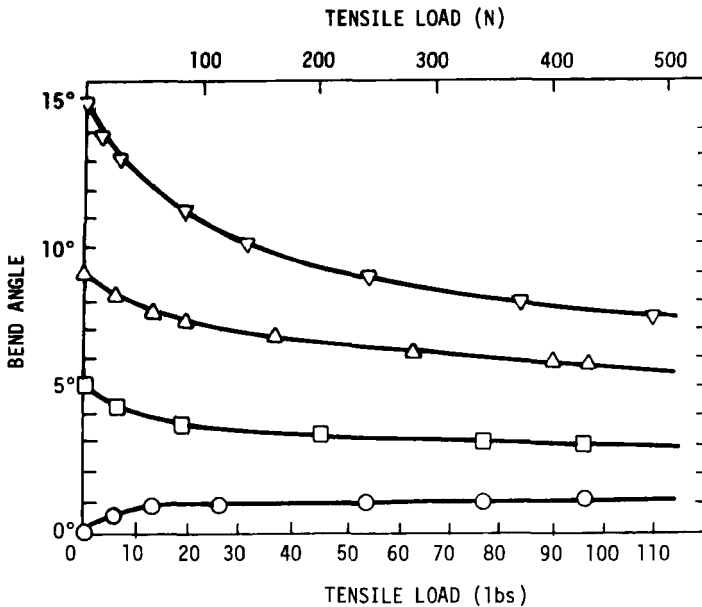

FIGURE 3 The Effect of Tensile Load on Bend Angle For Joints with Inflexible Adhesive Layers.

of a joint with inflexible bond is likely to decrease during loading. Such a behavior was observed during our experiments (Figure 3). Adherends with large prebent angles were subjected to high bending deformations which caused considerable decreases in bend angle. For example, at 110 lbs. (489 N) tensile load, a 15° prebent angle was reduced by 51% compared to a 42% reduction of a 5° angle (Figure 3).

The presence of high isochromatic fringe orders in the bent region of the 15° specimen, at higher load levels (at 100 lbs.; 445 N, and up in Figure 3) revealed the necessity for limiting the size of prebent angles, in order to avoid adherend failures.

### Comparison of Photoelastic Results With Goland and Reissner Theory

Two 0° specimens with 2.0 in. (50.8 mm) and 0.3 in. (7.6 mm) overlap lengths (Figure 4) were used to verify the accuracy of our photoelastic method. Goland and Reissner theory<sup>1</sup> predicts that the adhesive peak tearing stresses of a joint with inflexible adhesive layer will increase with an increase in tensile load and with a decrease in the overlap length. As seen in Figure 4, the isochromatic fringe orders, corresponding to the adhesive peak tearing stresses, in the joint with 0.3 in. (7.6 mm) overlap length were indeed

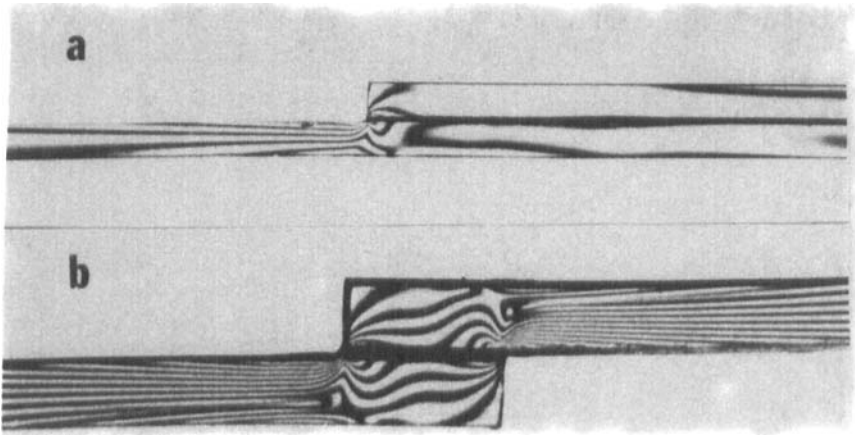

FIGURE 4 Isochromatic Fringe Patterns at 39 lb (173 N) Tensile Load for a) 2.0 in (50.8 mm) Overlap, b) 0.3 in (7.6 mm) Overlap.

higher than those in the 2.0 in. (50.8 mm) one, at constant load levels. Theory and experiment showed good agreement at all load levels, when tensile load *vs.* adhesive peak tearing stress behavior was plotted (Figure 5).

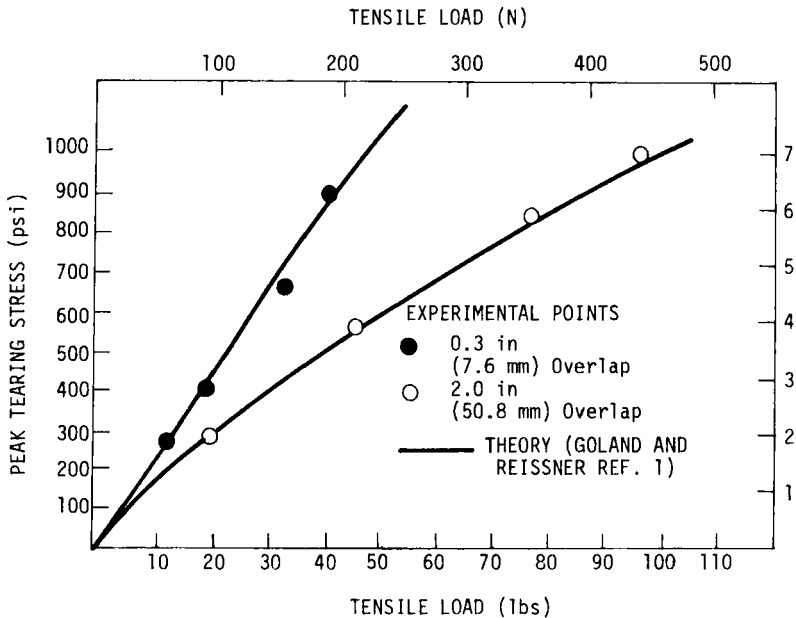

FIGURE 5 Comparison of the Photoelastic (Experimental) Results With Theory For Joints Without Prebent ( $0^\circ$ ).

## The Effect of Tensile Load on the Peak Tearing Stress at Different Prebent Angles

Isochromatic fringe order measurements revealed that the adhesive peak tearing stresses decreased with the use of prebent angles (Figure 6). The effect of tensile stresses for different prebent angles is shown in Figure 7. As can be seen in Figure 7, joints with prebent angles can bear load levels higher than those applied to the 0 degree one, before reaching the same peak tearing stress levels.

For joints with inflexible adhesive layers, theories of failure predict that fracture will occur at the point of peak tearing stress. This is due to the fact that, both theory<sup>1</sup> and our photoelastic experiments show, along the bondline, the tearing stress drops down to about 6% of its maximum edge-value when the shear stress reaches its peak, which is less than half the level of maximum tearing stress. Therefore, Figure 7 can be used to estimate the increase in load carrying capacity of joints with prebent angles and inflexible adhesive layers, as the adhesive peak tearing stresses are the critical stresses for failure. Since the proportional limit for the model material is  $\sim 3000$  psi (20.7 MPa), the stress range shown in Figure 7 represents working stresses, when safety factors of 3 or more are used. It should be noted, however, that this treatment assumes adherend failure will not occur.

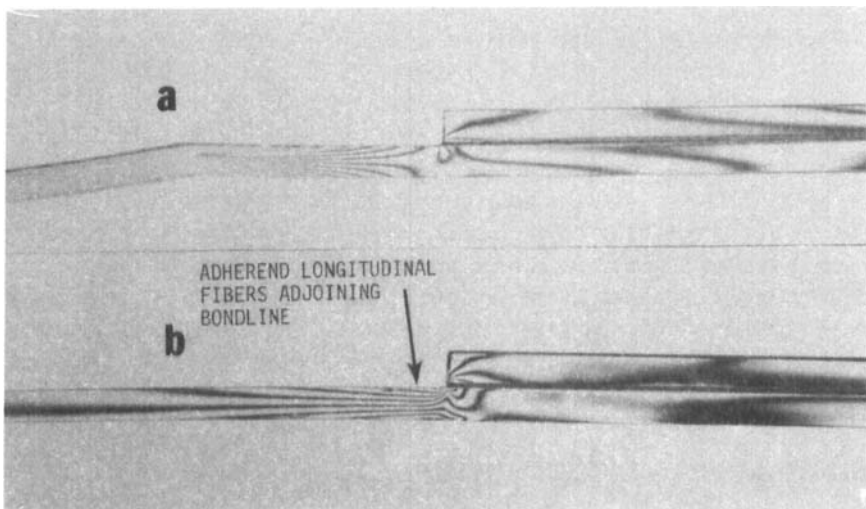

FIGURE 6 Isochromatic Fringe Patterns at 50 lb (223 N) Tensile Load for a) 15° Prebent, b) 0° Prebent.



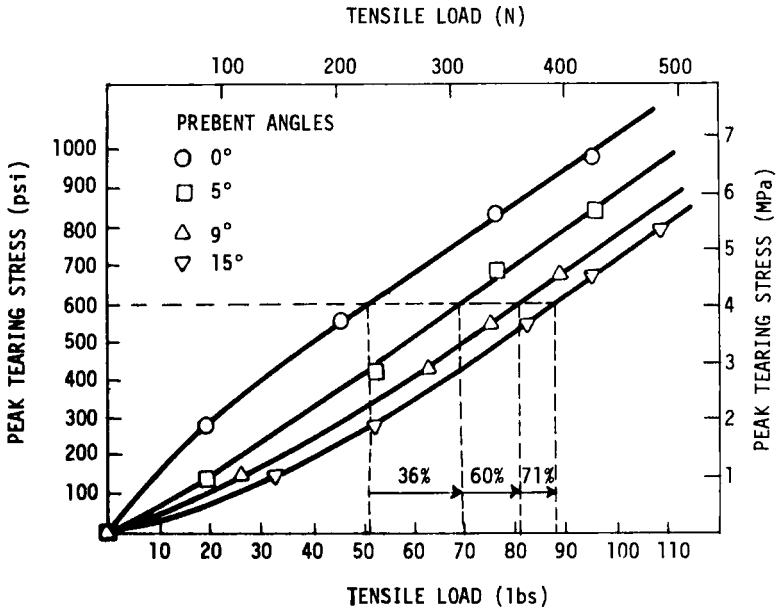

FIGURE 7 The Effect of Tensile Load on the Peak Tearing Stress For Joints With Inflexible Adhesive Layers.

Figure 7 shows that the use of 5, 9, and 15 degrees prebent angles result in 36%, 60%, and 71% increases, respectively, in the joint load carrying capacities.

The increase in the load carrying capacity gets smaller as the prebent angles get larger (Figure 7). This is due to the fact that the larger prebent angles are subjected to more bending deformations (Figure 3).

The high orders of isochromatic fringes observed in the prebent region (Figure 6a) indicate a possibility for adherend failure in that area. It should be noted, however, that the prebent angles also help lower the stress concentrations which exist on the adherend surfaces adjacent to the end of overlap region. These stress concentrations are due to the peak longitudinal stresses in the adherend fibers adjoining the adhesive layer. A comparison of the fringe orders on the adherend surfaces in Figure 6 indicates that the peak adherend longitudinal stresses are indeed reduced due to the presence of the prebend.

## SUMMARY AND CONCLUSIONS

The effects of prebent adherends on the overall joint performance were investigated with the use of model joints with inflexible adhesive layers.

Photoelastic methods were used to determine experimentally the magnitudes of adhesive peak tearing stresses. The experimental results for ordinary joints were compared with Goland and Reissner theory to verify the accuracy of the photoelastic method.

Results of the photoelastic experiments revealed that the load carrying capabilities of joints with inflexible adhesive layers were increased by as much as 71%. Examination of the fringe orders on the prebent area, however, indicated a possibility for adherend failure in that region.

Prebent angles were reduced as much as 50% during loading. This result indicated that the use of prebent angles larger than 15° would be very marginal and even critical due to a possible adherend failure.

### Acknowledgements

Financial support from Olin Corp. Trust for one of us is gratefully acknowledged.

### References

1. M. Goland and E. Reissner, "The Stresses in Cemented Joints," *Journal of Applied Mechanics*, Vol. II, No. 1, March 1944.
2. S. DasGupta and S. P. Sharma, "Stresses in an Adhesive Lap Joint," ASME Paper No. 75-WA-DE-18, 1975.
3. S. DasGupta, "Stresses in Adhesive Lap Joints With Prebent Adherends," ASME Paper No. 79-DET-105, 1979.
4. J. W. Dally and W. F. Riley, *Experimental Stress Analysis* (McGraw-Hill Book Co., N.Y., 1978).